

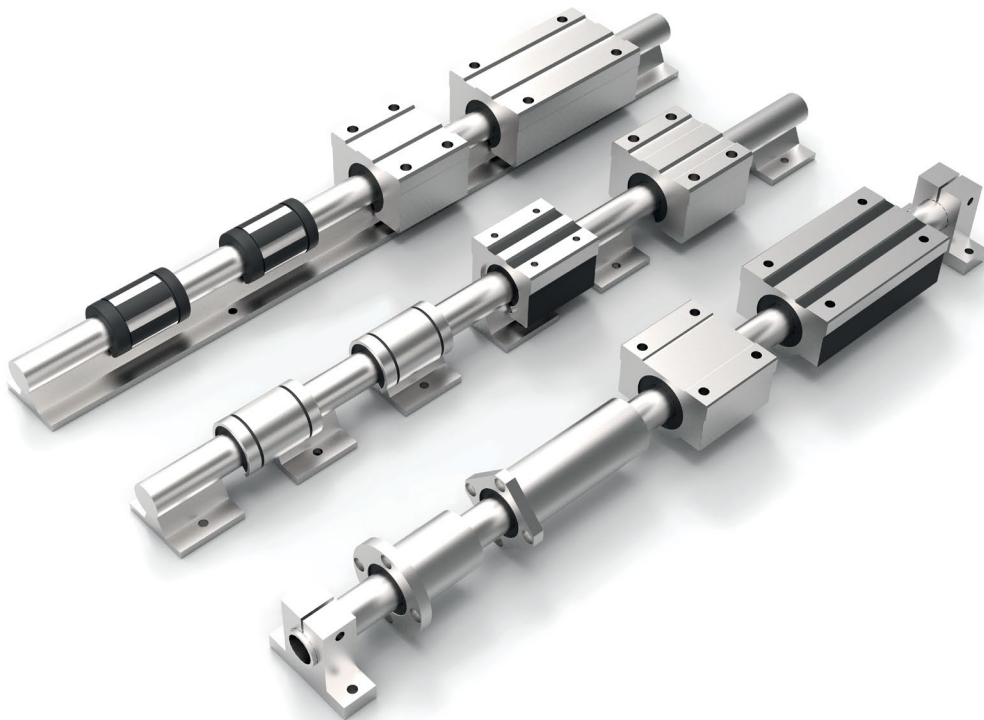



HepcoMotion®

Ball Bushings Range



Contents





Super Ball Bushing - European Standard



SBE - Super European Closed		2
SBEO - Super European Open		3
CS - Super European Pillow Block Closed		4
CSO - Super European Pillow Block Open		5

Standard Ball Bushing

LME - Standard European Closed		6-7
LME-OP - Standard European Open		6-7
LM - Standard Japanese Closed		8-9
LM-OP - Standard Japanese Open		8-9

Flanged Housing

LMF - Single Round Flanged		10-11
LMK - Single Square Flanged		10-11
LMF-L - Extended Length Round Flanged Units		12-13
LMK-L - Extended Length Square Flanged Units		12-13
LMEL - Extended Length B411 Bushing		14

HepcoMotion Precision Linear Shaft		15
Metric Shaft Support Rails		16
Aluminium Shaft Support		17
Housing and Shaft Tolerance		18-19
Assembly		18-19
Load / Life		20
Lubrication		21

HepcoMotion Standard Ball Bushings

Standard ball bushings from HepcoMotion offer dimensional interchangeability with all major manufacturers and incorporate a rigid steel outer sleeve with between 3 and 6 ball circuits depending on size. Ball retainers are made from high grade polyamide for superior performance and low friction.

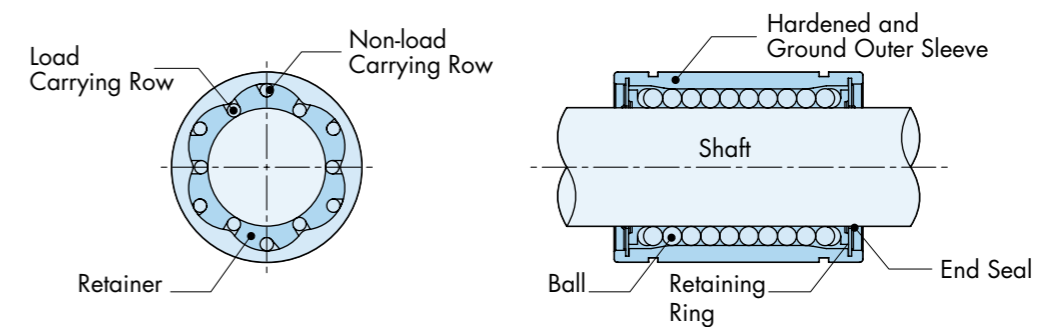

Fig 1. Linear Ball Bushing

HepcoMotion Super Ball Bushings

Super ball bushings from HepcoMotion offer approximately 3 times load capacity which equates to 27 times the life of standard ball bushings with the same overall dimensions. These high quality units consist of hardened steel segmented load bearing plates with precision ground ball tracks combined with a +/- 0.5 degree self alignment feature. This ensures a uniform load distribution over the entire row of balls, preventing point loading that shortens life.

Self Alignment Feature

The outer surface of the steel load bearing plates are designed with a curved surface that in turn allows the bushing to absorb misalignment caused by inaccuracies between the shaft and ball bushing. In addition to ensuring equal load distribution, the feature provides smooth entry and exit of the balls in and out of the loading area.

The self alignment feature requires two super ball bushings to be mounted to one shaft in a conventional two parallel shaft arrangement.

- Super ball bushings are interchangeable with the ISO standard. (All main dimensions, outside diameter, bore and length are the same).
- Super ball bushings will reduce preparation and assembly time, as any shaft deflection and inaccuracies in the machining process will be accommodated by the self alignment feature.
- Easy entry and exit ball feature.
- Ball retainers are made from a high grade polyamide maintaining low friction over the entire travel length.
- Friction coefficient of 0.001 with oil lubrication.
- Can operate at temperatures up to 100°C and speeds up to 3m/sec.

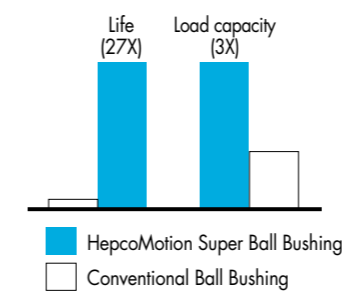

Fig 2. Comparing Life and Load Capacity

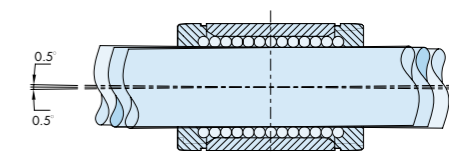
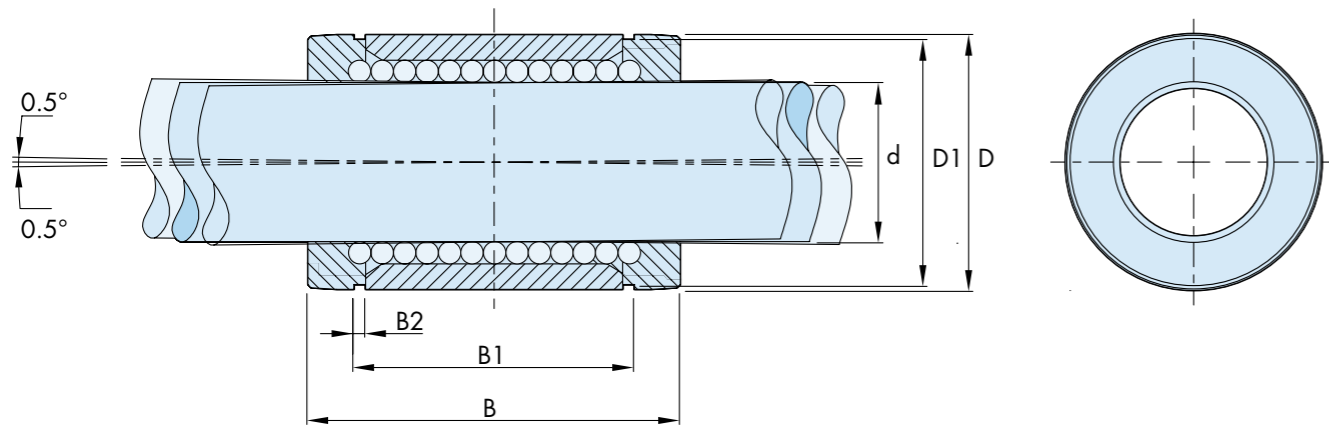

Fig 3. +/- 0.5° of Self-Alignment

SBE type - Super European Ball Bushing (self aligning) Closed Type



Part No.			Dimensions					Shaft	No. Ball Rows	Basic Load Ratings		Weight (g)
With Two Seals (Stock Range)	With One Seal	Without Seal	D	D1	B	B1	B2	d		dyn. C (N)	stat. Co (N)	
SBE16UU	SBE16U	SBE16	26	24.9	36	24.6	1.3	16	5	1140	710	26
SBE20UU	SBE20U	SBE20	32	30.5	45	31.2	1.6	20	6	2280	1400	60
SBE25UU	SBE25U	SBE25	40	38.5	58	43.7	1.85	25	6	4280	2740	120
SBE30UU	SBE30U	SBE30	47	44.5	68	51.7	1.85	30	6	5020	3365	184
SBE40UU	SBE40U	SBE40	62	58.5	80	60.3	2.15	40	6	8980	5460	342
SBE50UU	SBE50U	SBE50	75	71.5	100	77.3	2.65	50	6	12965	7940	586

SBEO type - Super European Ball Bushing (self aligning) Open Type

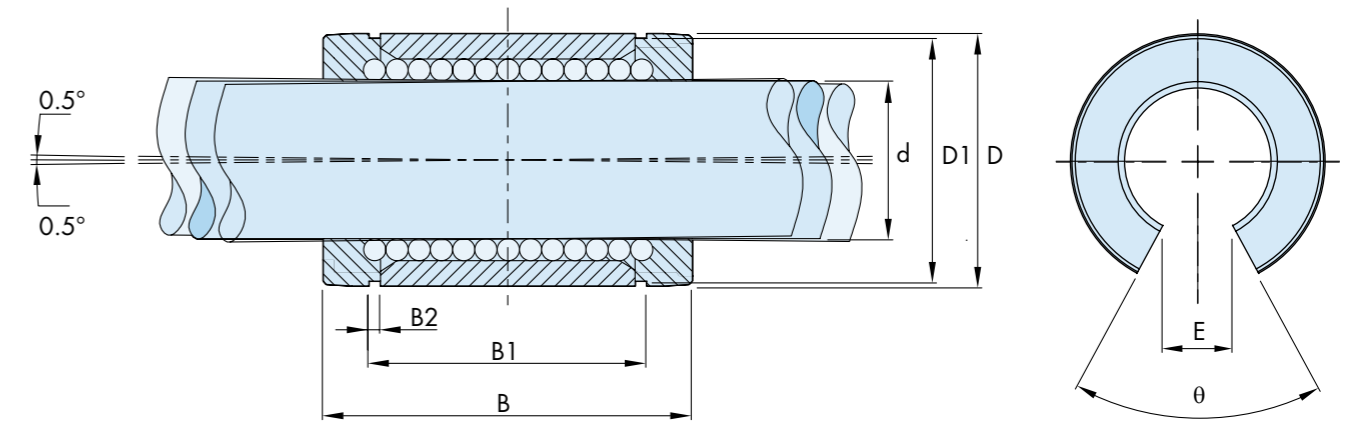
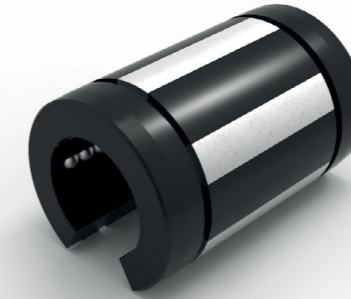

Part No.			Dimensions					Angle	Shaft	No. Ball Rows	Basic Load Ratings		Weight (g)	
With Two Seals (Stock Range)	With One Seal	Without Seal	D	D1	B	B1	B2	E	theta		d	dyn. C (N)		stat. Co (N)
SBEO16UU	SBEO16U	SBEO16	26	24.9	36	24.6	1.3	9	68°	16	4	1330	910	20
SBEO20UU	SBEO20U	SBEO20	32	30.5	45	31.2	1.6	9	55°	20	5	2310	1445	50
SBEO25UU	SBEO25U	SBEO25	40	38.5	58	43.7	1.85	11.5	57°	25	5	4330	2820	100
SBEO30UU	SBEO30U	SBEO30	47	44.5	68	51.7	1.85	14	57°	30	5	5080	3460	154
SBEO40UU	SBEO40U	SBEO40	62	58.5	80	60.3	2.15	19.5	56°	40	5	9095	5625	286
SBEO50UU	SBEO50U	SBEO50	75	71.5	100	77.3	2.65	22.5	54°	50	5	13130	8175	486

CS type - Super European Ball Bushing Pillow Block Closed Type

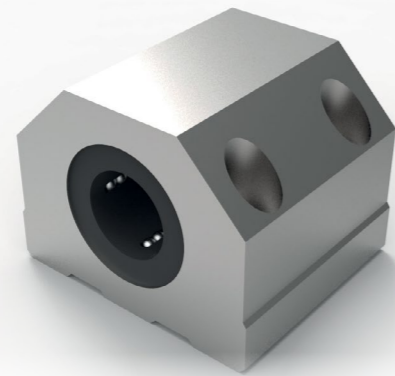

(with 1pc self aligning SBE ball bushing)

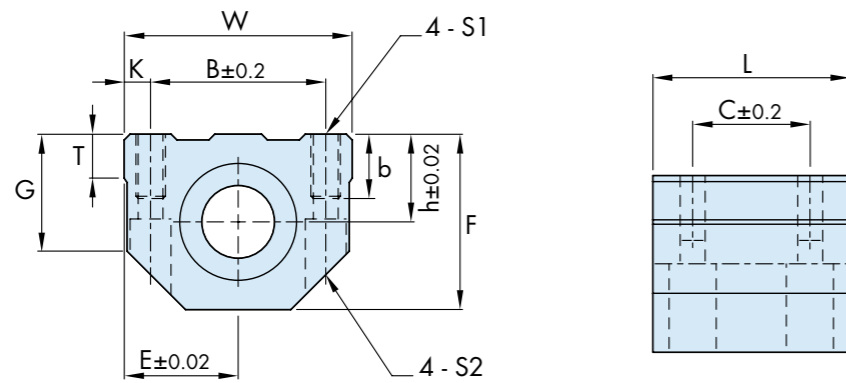

Part No.	Dimensions							Mounting Dimensions						Shaft	No. Ball Rows	Basic Load Ratings		Weight (g)
	h	E	W	L	F	G	T	B	C	K	b	S1	S2			dyn. C (N)	stat. Co (N)	
CS16UUB	22	26.5	53	43	42	29	10	40	26	6.5	13	M6	M5	16	5	1140	710	204
CS20UUB	25	30	60	54	50	34	12	45	32	7.5	18	M8	M6	20	6	2280	1400	340
CS25UUB	30	39	78	67	60	40	15	60	40	9	22	M10	M8	25	6	4280	2740	636
CS30UUB	35	43.5	87	79	70	48	17	68	45	9.5	22	M10	M8	30	6	5020	3365	970
CS40UUB	45	54	108	91	90	62	22	86	58	11	26	M12	M10	40	6	8980	5460	1740
CS50UUB	50	66	132	113	105	68	25	108	50	12	34	M16	M12	50	6	12965	7940	2922

CSO type - Super European Ball Bushing Pillow Block Open Type

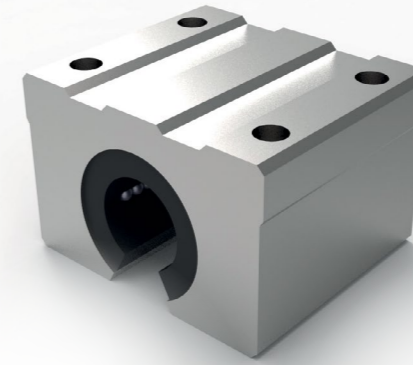

(with 1pc self aligning SBEO ball bushing)

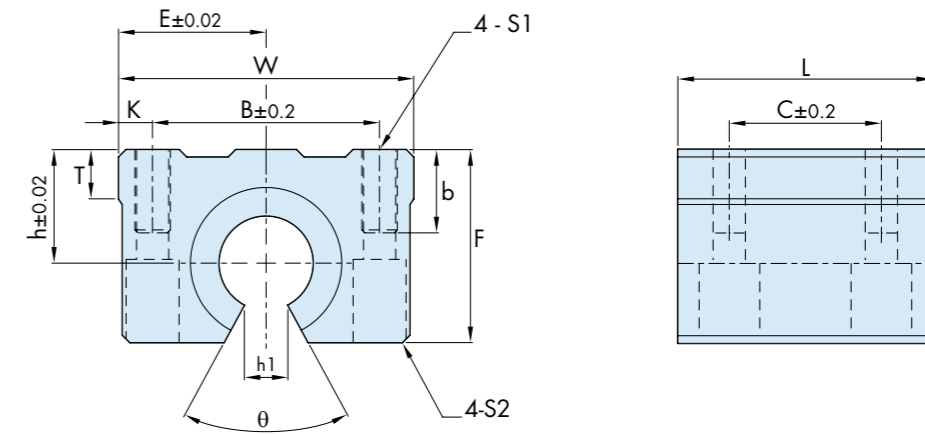

Part No.	Dimensions							Mounting Dimensions						Shaft	No. Ball Rows	Basic Load Ratings		Weight (g)	
	h	E	W	L	F	T	h ₁	θ	B	C	K	b	S1			S2	dyn. C (N)		stat. Co (N)
CSO16UUB	22	26.5	53	43	35	8	9	68°	40	26	6.5	13	M6	M5	16	4	1330	910	160
CSO20UUB	25	30	60	54	42	10	9	55°	45	32	7.5	18	M8	M6	20	5	2310	1445	280
CSO25UUB	30	39	78	67	51	13	11.5	57°	60	40	9	22	M10	M8	25	5	4330	2820	552
CSO30UUB	35	43.5	87	79	60	15	14	57°	68	45	9.5	22	M10	M8	30	5	5080	3460	846
CSO40UUB	45	54	108	91	77	20	19.5	56°	86	58	11	26	M12	M10	40	5	9095	5625	1516
CSO50UUB	50	66	132	113	88	25	22.5	54°	108	50	12	34	M16	M12	50	5	13130	8175	2546

LME Series - Standard European Ball Bushing



LME

LME OP

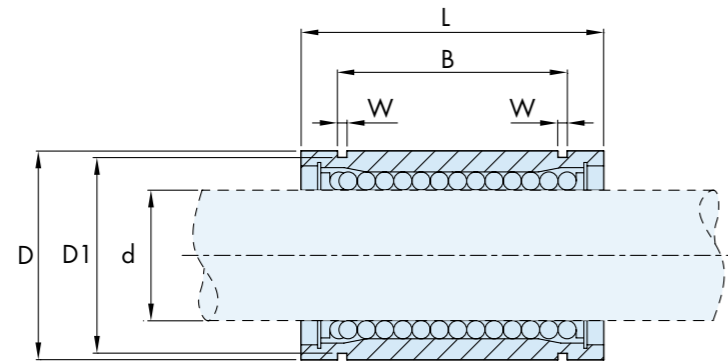

LME Series				Basic Load Ratings		Working Bore Diameter
Standard Type		Open Type		dyn. C (N)	stat. Co (N)	d (mm)
Part No.	No. of Ball Circuit	Part No.	No. of Ball Circuit			
LME5UU	4	-	-	200	260	5
LME8UU	4	-	-	260	400	8
LME12UU	4	LME12UUOP	3	410	590	12
LME16UU	5	LME16UUOP	4	770	1170	16
LME20UU	5	LME20UUOP	4	860	1370	20
LME25UU	6	LME25UUOP	5	980	1560	25
LME30UU	6	LME30UUOP	5	1560	2740	30
LME40UU	6	LME40UUOP	5	2150	4010	40
LME50UU	6	LME50UUOP	5	3280	7930	50
LME60UU	6	LME60UUOP	5	4700	9990	60

LME Series - Standard European Ball Bushing

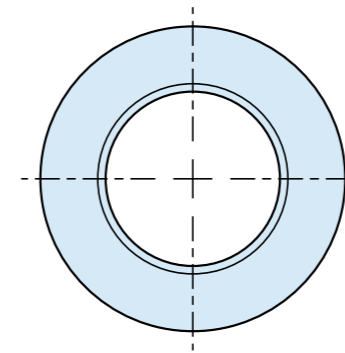

LME

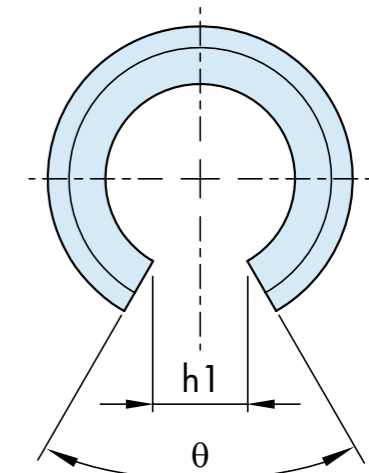

LME OP

Part No.	Part No.	Dimensions (mm)										Weight (g)
		D		L		B		W	D1	h1	θ	
		(mm)	Tol (μm)	(mm)	Tol (mm)	(mm)	Tol (mm)					
LME5UU	-	12	0	22	0	14.5	0	1.1	11.5	-	-	12
LME8UU	-	16	-8	25	0	16.5	-0.2	1.1	15.2	-	-	20
LME12UU	LME12UUOP	22	0	32	-0.2	22.9	0	1.3	21	7.5	78°	41
LME16UU	LME16UUOP	26	-9	36	0	24.9	-0.2	1.3	24.9	10	78°	57
LME20UU	LME20UUOP	32	0	45	0	31.5	0	1.6	30.3	10	60°	91
LME25UU	LME25UUOP	40	-11	58	0	44.1	0	1.85	37.5	12.5	60°	215
LME30UU	LME30UUOP	47	0	68	-0.3	52.1	0	1.85	44.5	12.5	50°	325
LME40UU	LME40UUOP	62	0	80	-0.3	60.6	-0.3	2.15	59	16.8	50°	705
LME50UU	LME50UUOP	75	-13	100	0	77.6	0	2.65	72	21	50°	1130
LME60UU	LME60UUOP	90	0	125	-0.4	101.7	0	3.15	86.5	27.2	54°	2220



LM

LM OP

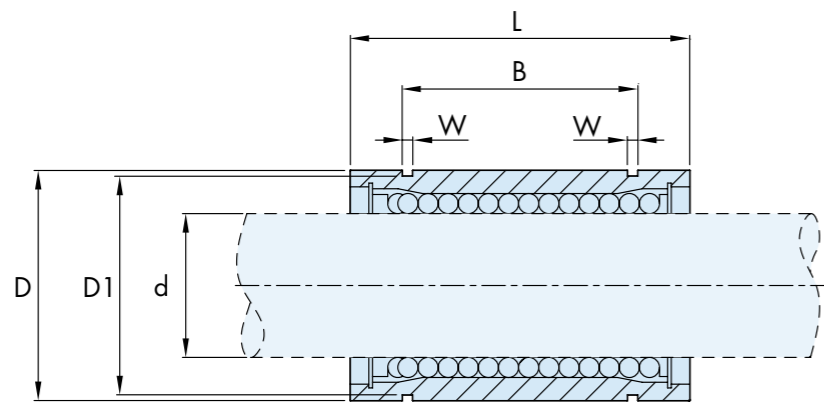

LM Series				Basic Load Ratings		Working Bore Diameter
Standard Type		Open Type		dyn. C (N)	stat. Co (N)	d (mm)
Part No.	No. of Ball Circuit	Part No.	No. of Ball Circuit			
LM4UU	4	-	-	88	108	4
LM5UU	4	-	-	167	206	5
LM6UU	4	-	-	200	260	6
LM8SUU	4	-	-	170	220	8
LM8UU	4	-	-	260	400	8
LM10UU	4	-	-	370	540	10
LM12UU	4	LM12UUOP	3	410	590	12
LM13UU	4	LM13UUOP	3	500	770	13
LM16UU	5	LM16UUOP	4	770	1170	16
LM20UU	5	LM20UUOP	4	860	1370	20
LM25UU	6	LM25UUOP	5	980	1560	25
LM30UU	6	LM30UUOP	5	1560	2740	30
LM35UU	6	LM35UUOP	5	1660	3130	35
LM40UU	6	LM40UUOP	5	2150	4010	40
LM50UU	6	LM50UUOP	5	3820	7930	50
LM60UU	6	LM60UUOP	5	4700	9990	60

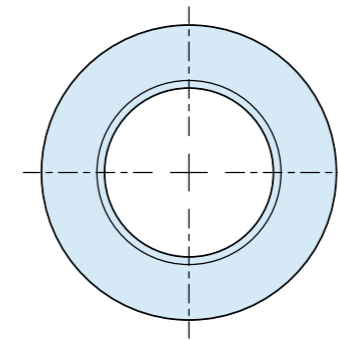

LM

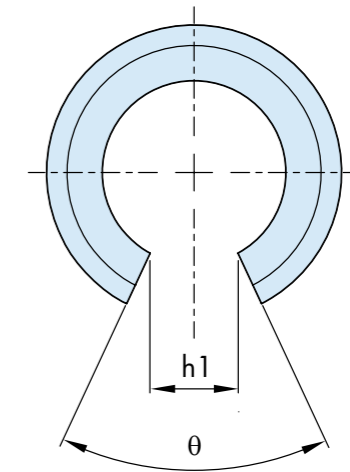

LM OP

Part No.	Part No.	Dimensions (mm)										Weight (g)		
		D		L		B		W	D1	h1	θ			
(mm)	Tol. (μm)	(mm)	Tol. (mm)	(mm)	Tol. (mm)	(mm)	(mm)					(mm)	(mm)	(mm)
LM4UU	-	8	0 -9	12	0 -0.12	-	-	-	-	-	-	-	1.9	
LM5UU	-	10	0 -8	15	0 -0.12	10.2	-	1.1	9.6	-	-	-	4	
LM6UU	-	12	0 -11	19	0 -0.2	13.5	0 -0.2	1.1	11.5	-	-	-	8	
LM8SUU	-	15		17		11.5		1.1	14.3	-	-	-	-	11
LM8UU	-	15		24		17.5		1.1	14.3	-	-	-	-	16
LM10UU	-	19	0 -13	29	0 -0.2	22	0 -0.2	1.3	18	-	-	-	30	
LM12UU	LM12UUOP	21		30		23		1.3	20	8	80°	-	-	31.5
LM13UU	LM13UUOP	23		32		23		1.3	22	9	80°	-	-	43
LM16UU	LM16UUOP	28	0 -16	37	0 -0.3	26.5	0 -0.3	1.6	27	11	80°	-	69	
LM20UU	LM20UUOP	32		42		30.5		1.6	30.5	11	60°	-	-	87
LM25UU	LM25UUOP	40		59		41		1.85	38	12	50°	-	-	220
LM30UU	LM30UUOP	45	0 -19	64	0 -0.3	44.5	0 -0.3	1.85	43	15	50°	-	250	
LM35UU	LM35UUOP	52		70		49.5		2.1	49	17	50°	-	-	390
LM40UU	LM40UUOP	60		80		60.5		2.1	57	20	50°	-	-	585
LM50UU	LM50UUOP	80	0 -22	100	0 -0.3	74	0 -0.3	2.6	76.5	25	50°	-	1580	
LM60UU	LM60UUOP	90		110		85		3.15	86.5	30	50°	-	-	2000

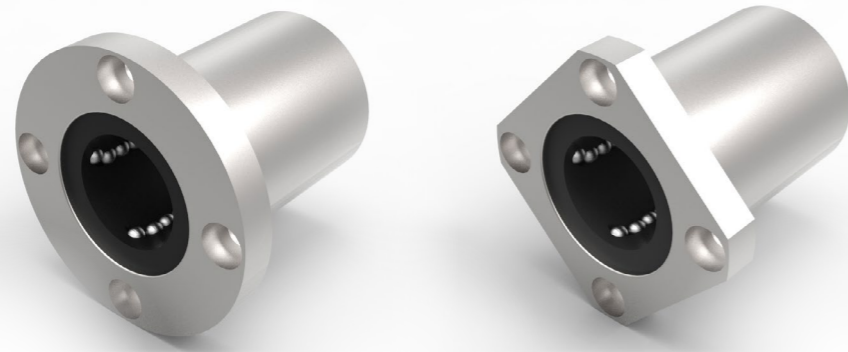

LMF

LMK

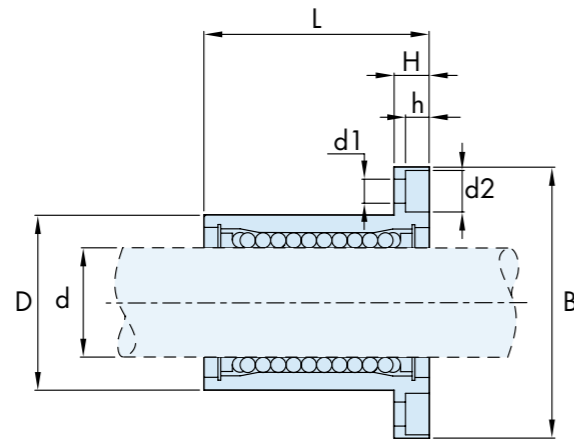

Part No.		No. of Ball Circuit	Weight (g)	Basic Load Ratings		Working Bore Diameter
Circular type	Square type			Dyn. C (N)	Stat. Co (N)	d (mm)
LMF6UU	LMK6UU	4	26.5	200	260	6
LMF8UU	LMK8UU	4	40	260	400	8
LMF10UU	LMK10UU	4	78	370	540	10
LMF12UU	LMK12UU	4	76	410	590	12
LMF13UU	LMK13UU	4	94	500	770	13
LMF16UU	LMK16UU	5	134	770	1170	16
LMF20UU	LMK20UU	5	180	860	1370	20
LMF25UU	LMK25UU	6	340	980	1560	25
LMF30UU	LMK30UU	6	460	1560	2740	30
LMF35UU	LMK35UU	6	795	1660	3130	35
LMF40UU	LMK40UU	6	1054	2150	4010	40
LMF50UU	LMK50UU	6	2200	3820	7930	50
LMF60UU	LMK60UU	6	2960	4700	9990	60

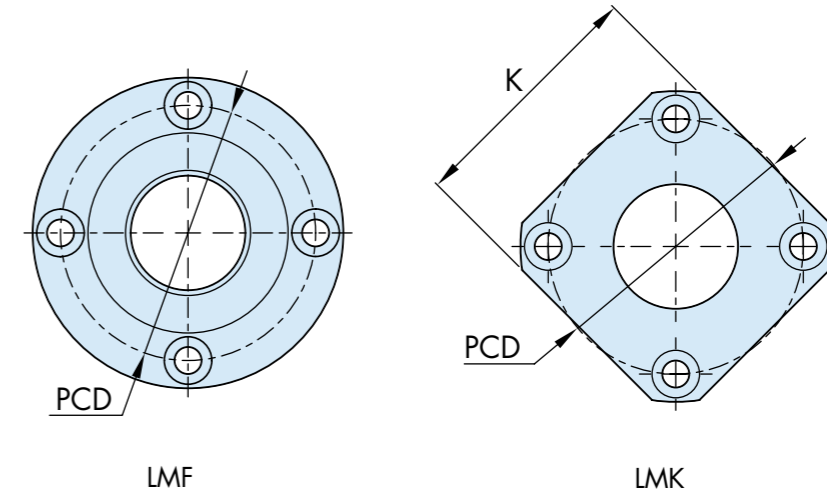

LMF

LMK

Part No.		Dimensions (mm)								
		D		L		B	H	PCD	K	d1 x d2 x h
Circular type	Square type	(mm)	Tol. (µm)	(mm)	Tol. (mm)	(mm)				
LMF6UU	LMK6UU	12	0	19	0 -0.2	28	5	20	22	3.4 x 6.5 x 3.3
LMF8UU	LMK8UU	15	-11	24		32	5	24	25	3.4 x 6.5 x 3.3
LMF10UU	LMK10UU	19		29		40	6	29	30	4.5 x 8 x 4.4
LMF12UU	LMK12UU	21	0	30		42	6	32	32	4.5 x 8 x 4.4
LMF13UU	LMK13UU	23	-13	32		43	6	33	34	4.5 x 8 x 4.4
LMF16UU	LMK16UU	28		37		48	6	38	37	4.5 x 8 x 4.4
LMF20UU	LMK20UU	32		42	54	8	43	42	5.5 x 9.5 x 5.4	
LMF25UU	LMK25UU	40	0	59	0 -0.3	62	8	51	50	5.5 x 9.5 x 5.4
LMF30UU	LMK30UU	45	-16	64		74	10	60	58	6.6 x 11 x 6.5
LMF35UU	LMK35UU	52		70		82	10	67	64	6.6 x 11 x 6.5
LMF40UU	LMK40UU	60	0	80		96	13	78	75	9 x 14 x 8.6
LMF50UU	LMK50UU	80	-19	100		116	13	98	92	9 x 14 x 8.6
LMF60UU	LMK60UU	90	0	110		134	18	112	106	11 x 17.5 x 10.8

LMF/KL Series - Extended Length Flanged Units



LMF L

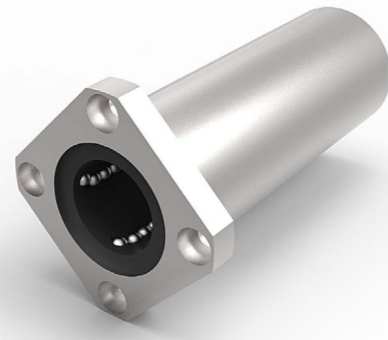

LMK L

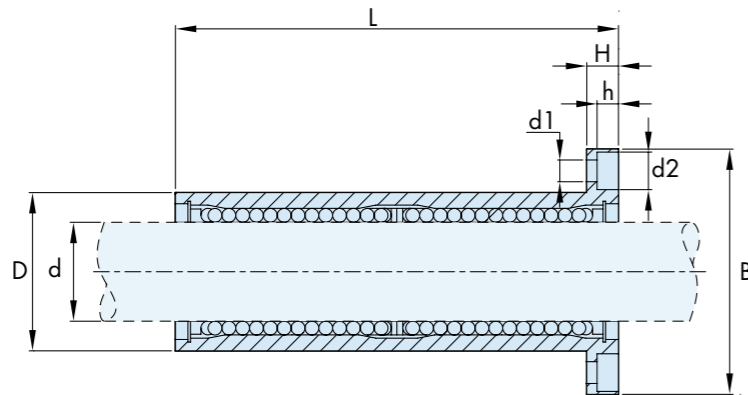

Part No.		No. of Ball Circuit	Weight (g)	Basic Load Ratings		Working Bore Diameter d (mm)
Circular Type	Square Type			dyn. C (N)	stat. Co (N)	
LMF6LUU	LMK6LUU	4	31	320	520	6
LMF8LUU	LMK8LUU	4	53	430	780	8
LMF10LUU	LMK10LUU	4	105	580	1100	10
LMF12LUU	LMK12LUU	4	100	650	1200	12
LMF13LUU	LMK13LUU	4	130	810	1570	13
LMF16LUU	LMK16LUU	5	187	1230	2350	16
LMF20LUU	LMK20LUU	5	260	1400	2750	20
LMF25LUU	LMK25LUU	6	515	1560	3140	25
LMF30LUU	LMK30LUU	6	655	2490	5490	30
LMF35LUU	LMK35LUU	6	970	2650	6470	35
LMF40LUU	LMK40LUU	6	1560	3430	8040	40
LMF50LUU	LMK50LUU	6	3500	6080	15900	50
LMF60LUU	LMK60LUU	6	4500	7650	20000	60

LMF/KL Series - Extended Length Flanged Units

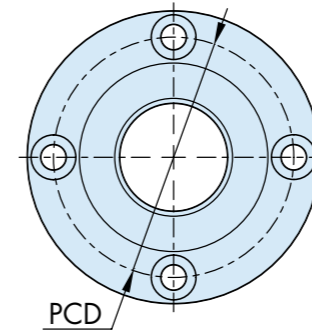

LMFL

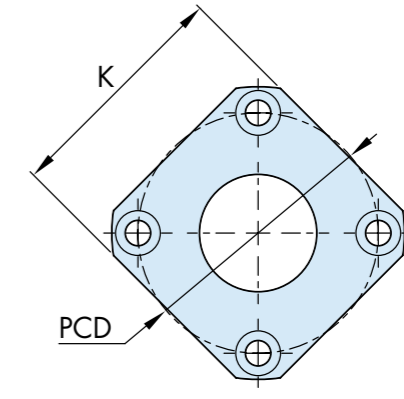

LMKL

Part No.		Dimensions (mm)								
Circular Type	Square Type	D		L		B	H	PCD	K	d1 x d2 x h
		(mm)	Tol. (mm)	(mm)	Tol. (mm)					
LMF6LUU	LMK6LUU	12	0	35	-0.3	28	5	20	22	3.4 x 6.5 x 3.3
LMF8LUU	LMK8LUU	15	-13	45		32	5	24	25	3.4 x 6.5 x 3.3
LMF10LUU	LMK10LUU	19	-16	55		40	6	29	30	4.5 x 8 x 4.4
LMF12LUU	LMK12LUU	21		0	57	42	6	32	32	4.5 x 8 x 4.4
LMF13LUU	LMK13LUU	23		-16	61	43	6	33	34	4.5 x 8 x 4.4
LMF16LUU	LMK16LUU	28	-16	70	48	6	38	37	4.5 x 8 x 4.4	
LMF20LUU	LMK20LUU	32		0	80	54	8	43	42	5.5 x 9.5 x 5.4
LMF25LUU	LMK25LUU	40		-16	112	62	8	51	50	5.5 x 9.5 x 5.4
LMF30LUU	LMK30LUU	45	-19	123	74	10	60	58	6.6 x 11 x 6.5	
LMF35LUU	LMK35LUU	52		0	135	82	10	67	64	6.6 x 11 x 6.5
LMF40LUU	LMK40LUU	60		-19	154	96	13	78	75	9 x 14 x 8.6
LMF50LUU	LMK50LUU	80	-22	192	116	13	98	92	9 x 14 x 8.6	
LMF60LUU	LMK60LUU	90		0	211	134	18	112	106	11 x 17.5 x 10.8

LME Series - Extended Length Ball Bushing

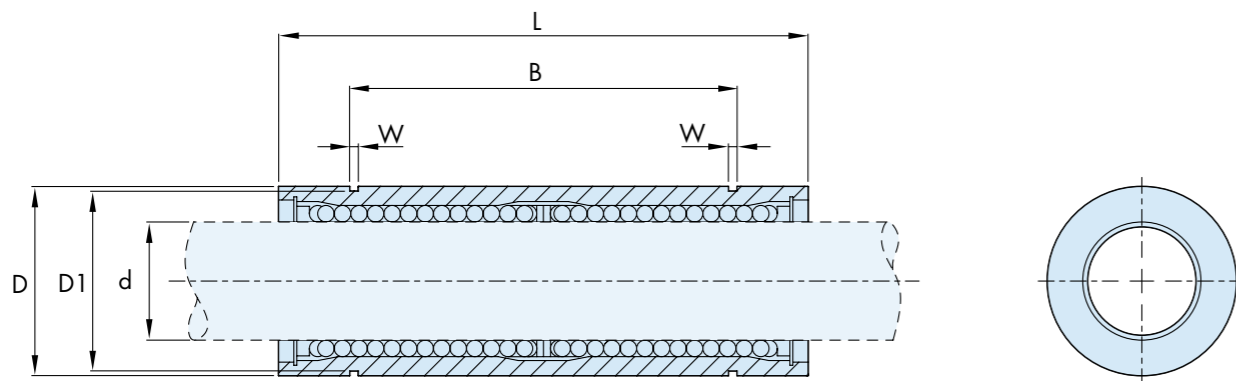

LML Series		Working Bore Diameter	Dimensions (mm)								Basic Load Ratings		
Part No.	No. of Ball Circuit		D		L		B		W	D1	Weight (g)	dyn. C (N)	stat. Co (N)
		d (mm)	(mm) Tol. (µm)	(mm) Tol. (mm)	(mm) Tol. (mm)	(mm) Tol. (mm)	(mm) Tol. (mm)						
LME8LUU	4	8	16	0 -9	46	0 -0.3	33	0 -0.3	1.1	15.2	40	421	804
LME12LUU	4	12	22	0 -11	61		45.8		1.3	21	80	813	1570
LME16LUU	5	16	26	0 -13	68	0 -0.4	49.8	0 -0.4	1.3	24.9	115	921	1780
LME20LUU	5	20	32		80		61		1.6	30.3	180	1370	2740
LME25LUU	6	25	40	0 -15	112	0 -0.4	82	0 -0.4	1.85	38	430	1570	3140
LME30LUU	6	30	47		123		104.2		1.85	44.5	615	2500	5490
LME40LUU	6	40	62	0 -20	151	0 -0.4	121.2	0 -0.4	2.15	59	1400	3430	8040
LME50LUU	6	50	75		192		155.2		2.65	72	2320	6080	15900
LME60LUU	6	60	90		209		170		3.15	86.5	3900	7550	20000

Precision Linear Shaft

Correct shaft selection is vital if maximum performance is to be achieved from our linear system. Hepco Precision Shaft has been developed to provide excellent performance when used with either recirculating ball bushings or plain bearing technology.

An extensive range of shaft materials are available and HepcoMotion offers a full machining facility with fast turnaround.

Other types of shaft available include:

- Specials (up to 150mm Ø).
- Tubing (Please enquire).



Shaft Type: Metric	Part Ref.	Hardness RC	TOL	Diameter Options																		
				4	5	6	8	10	12	13	16	20	25	30	35	40	50	60	80			
Metric Carbon Steel CK53 Hardened and Ground	NIMxx	60	h6	√	√	√	√	√	√	√	√	√	√	√	√	√	√	√	√	√	√	
Metric Stainless Steel (400 series) Hardened and Ground	NIMxx-SS	50	h6	√	√	√	√	√	√	√	√	√	√	√	√	√	√	√	√	√	√	√
Metric Soft Stainless Steel (300 Series) Ground	NIMxx-SS316	X	h6	√	√	√	√	√	√	√	√	√	√	√	√	√	√	√	√	√	√	√
Metric Hardcoat Anodised Aluminium	NI-MAxx	X	h6	-	-	-	√	√	√	-	√	√	√	-	-	-	-	-	-	-	-	-

Shaft Type: Imperial	Part Ref.	Hardness RC	TOL	Diameter Options												
				3/16	1/4	3/8	1/2	5/8	3/4	1	1 1/4	1 1/2	2			
Imperial Carbon Steel CK53 Hardened and Ground	NILxx	60	Class L	√	√	√	√	√	√	√	√	√	√	√	√	√
Imperial Stainless Steel (400 Series) Hardened and Ground	NILxx-SS	50	Class L	√	√	√	√	√	√	√	√	√	√	√	√	√
Imperial Soft Stainless Steel (300 Series) Ground	NILxx-SS316	X	Class L	√	√	√	√	√	√	√	√	√	√	√	√	√
Imperial Hardcoat Anodised Aluminium	NILAxx	X	Class L	√	√	√	√	√	√	√	√	√	√	√	√	√

Metric Shaft Support Rails

Shaft support rails will prevent shaft deflection under load and provide a high level of rigidity in order to achieve optimum performance from your open type Hepco Ball Bushing or any other open recirculating or plain linear bushing.

Support Rails are of low overall height making them particularly suitable for use with Hepco Pillow Blocks. The standard support rail is manufactured from aluminium alloy and comes in 600mm lengths only. These are then cut/butted together to fit to the overall length of the one piece shaft.

All types of shaft can be supplied drilled for customer assembly or fitted to the support rails for ease of supply.

For standard 600mm aluminium support rails, X = half of T1 or T2. For support rails which require cutting/butting, please confirm Dimension X when ordering.

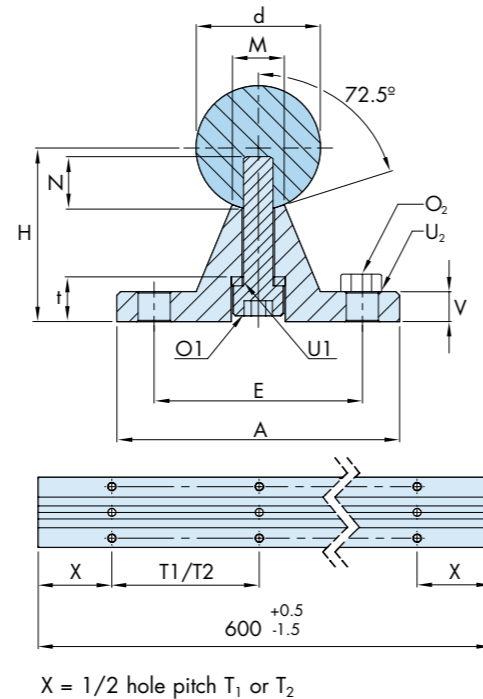

For Shaft Diameter	d	H ₁ ±0.01	A	V	M	O ₁	U ₁	N	E	t	O ₂	U ₂	T1	T2
12	12	22	40	5	5.8	M4x20	4	8	29	4.5	M4	4	75	120
16	16	26	45	5	7	M5x20	5	9	33	7.6	M5	5	100	150
20	20	32	52	6	8.3	M6x25	6	11	37	8.6	M6	6	100	150
25	25	36	57	6	10.8	M8x30	8	15	42	9	M6	6	120	200
30	30	42	69	7	11	M10x35	10	17	51	10	M8	8	150	200
40	40	50	73	8	15	M10x40	10	19	55	9.5	M8	8	200	300
50	50	60	84	9	19	M12x45	12	21	63	11.2	M10	10	200	300

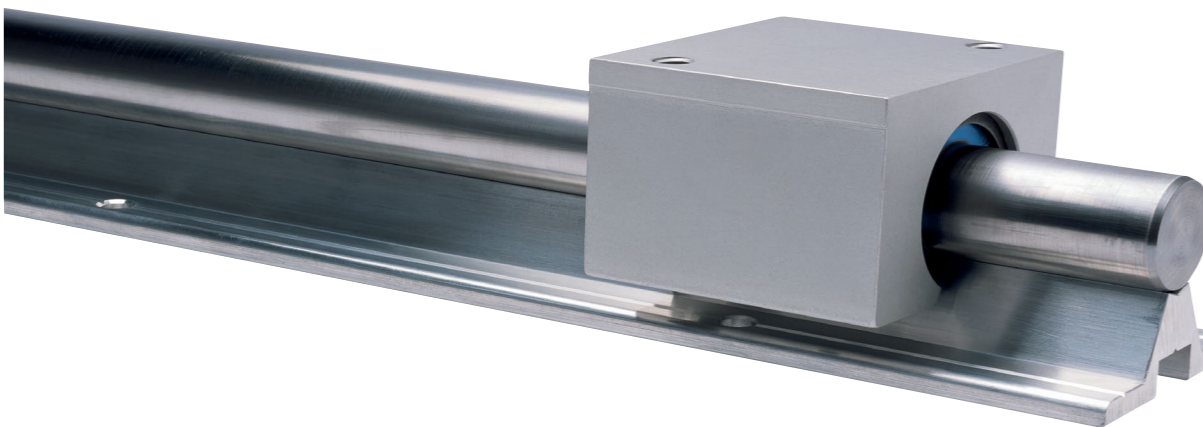

Ordering Shaft

Shaft & Support Rail Fully Assembled

Simply prefix the shaft reference with AU.
Example - AU NIM 20 X L2000 T2

Drilled Shaft Only

Simply state the shaft reference and add T1 or T2 depending upon shaft hole centres required.
Example - NIM 20 X L2000 T2

Support Rails Only

Aluminium Support Rails (SR) supplied in lengths up to 2000mm. Simply state whether T1 or T2 mounting hole spacing is required.
Example - Support Rail for 20mm Shaft T2
Hole Centre - SR20 - T2

Aluminium Shaft Supports

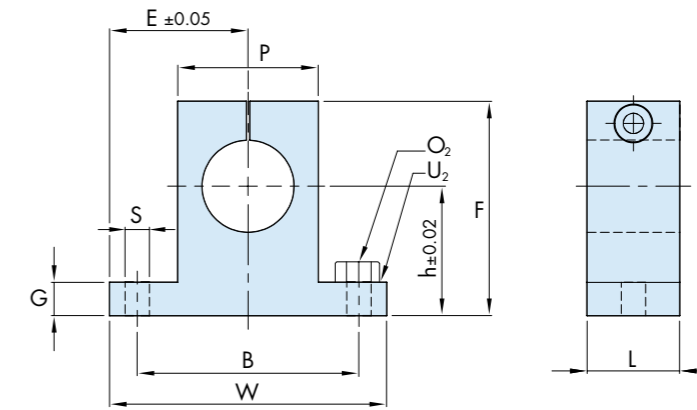

Part No.	Nominal Shaft Diameter	Major Dimensions									O ₂	U ₂	Weight (g)
		h	E	W	L	F	G	P	B	S			
ASS10	10	17	18.5	37	10	30	5	18	28	4.5	M4	4	24
ASS12	12	20	21	42	15	35	5.5	20	32	5.5	M5	5	30
ASS16	16	25	25	50	15	42	6	26	40	5.5	M5	5	40
ASS20	20	30	30	60	20	50	8	32	45	5.5	M5	5	70
ASS25	25	35	37	75	25	58	9	38	60	6.6	M6	6	130
ASS30	30	40	42	84	30	68	10	45	68	9	M8	8	180
ASS40	40	50	54	108	30	86	12	56	86	11	M10	10	420
ASS50	50	60	65	130	40	100	14	80	108	11	M10	10	750

Machined Ends

HepcoMotion can undertake shaft machining to standard ends as shown below or specials to customers' drawings.

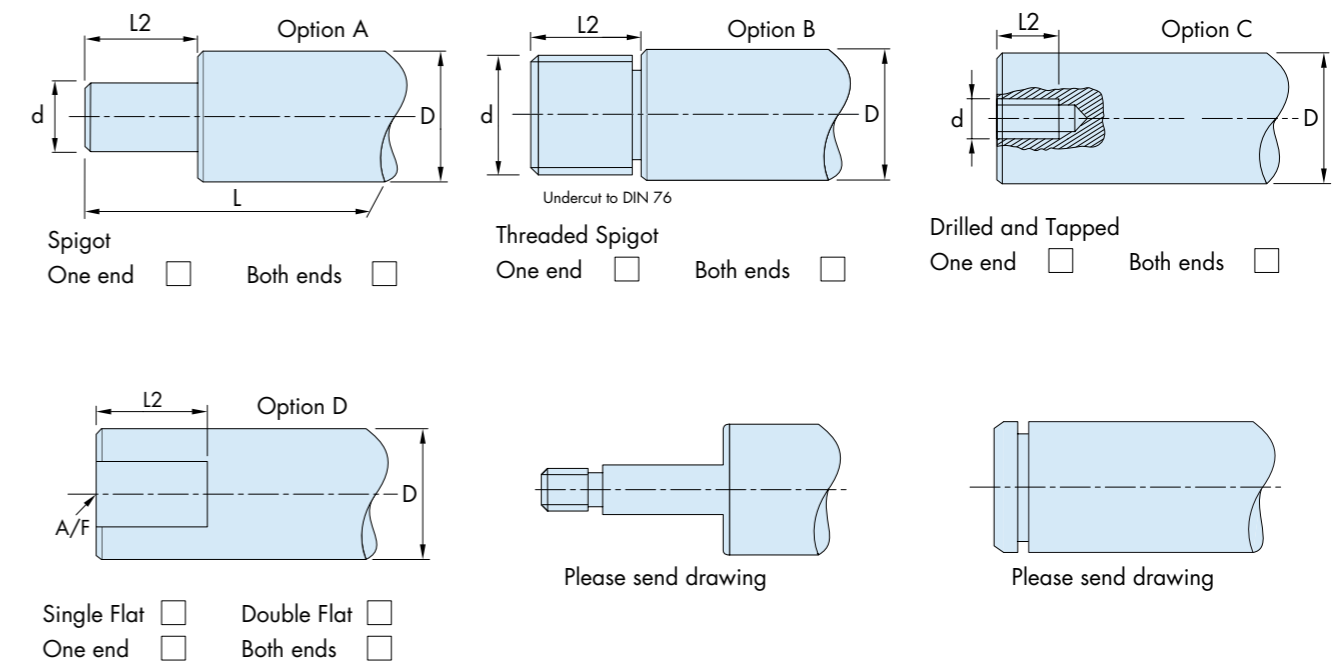

Housing and Shaft Tolerance - Super Ball Bushing

The recommended housing and shaft tolerances for Super Ball Bushings are shown in table 1.

Table 1. Super Ball Bushing SBE/SBEO

Part No.	16	20	25	30	40	50
Outer Diameter (D)	26	32	40	47	62	75
Housing Bore (H7)	+0.021 0		+0.025 0		+0.030 0	
Shaft Tol (h6)	✓		✓		✓	

Assembly - Super Ball Bushing

Use of a jig (see figure 5) is recommended for insertion into a housing. Care should be taken not to exert pressure on the ball retainer or seals.

The edge of the housing bore must be chamfered. Correct alignment is essential in order to prevent damage.

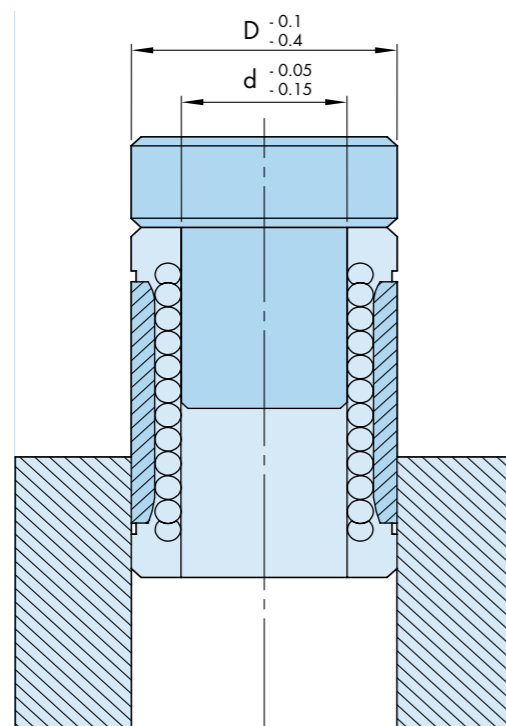

Fig 5. Use of a Jig

Housing and Shaft Tolerance - Standard Ball Bushing

The recommended housing and shaft tolerances for Standard Ball Bushings are shown in table 2.

Table 2. Standard Ball Bushing LME/LME-OP

Part No.	5	8	12	16	20	25	30	40	50	60
Outer Diameter (D)	12	16	22	26	32	40	47	62	75	90
Housing Bore (H7)	+0.018 0		+0.021 0		+0.025 0		+0.030 0		+0.035 0	
Shaft Tol (h6)	✓		✓		✓		✓		✓	

Assembly - Standard Bull Bushing

Possible mounting methods are illustrated in Figure 6. and Figure 7. with retaining rings and cover plates.

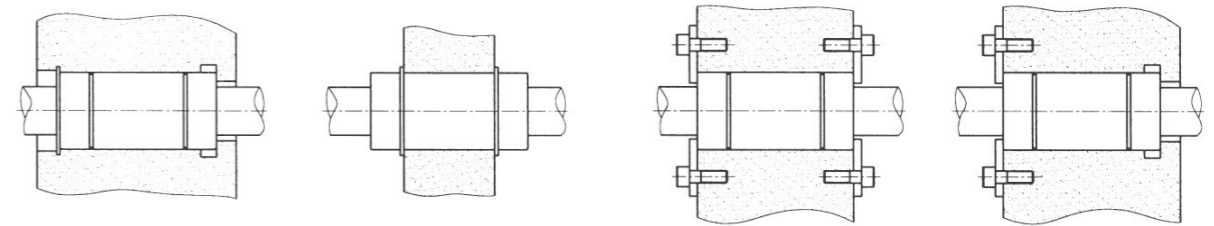

Fig 6. Mounting With Retaining Rings

Fig 7. Mounting With Cover Plates

Load / Life Calculation

Basic Dynamic Rating (C)

The basic Dynamic Load Rating (C) is the maximum continuous load that can be applied to a bearing with a 90% probability that a working life of 50 km will be achieved.

There are two key factors to the load calculation that may need to be applied depending on the application conditions.

Shaft hardness factor (FH)

The hardness of the shaft should be 60 RC +/- 2, refer to figure 8 for shaft hardness factors.

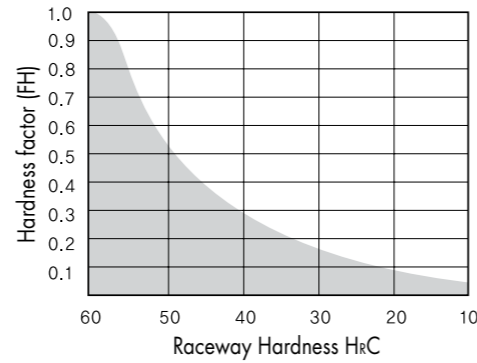

Fig 8. Hardness Factor (FH)

Temperature factor (FT)

$$L = \left(\frac{C}{P} \cdot FH \cdot FT \right)^3 \cdot 50 \text{ (km)}$$

- L : Running distance life (km)
- C : Basic dynamic load rating (N)
- P : Applied load (N)
- FH : Hardness factor (figure 8)
- FT : Temperature factor (figure 9)

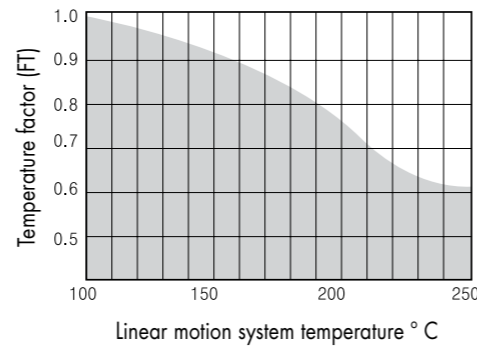

Fig 9. Temperature Factor (FT)

Ball bushings in this range are designed to work at a maximum temperature of 100 degrees C, for temperatures higher than this please apply the temperature factor as indicated in figure 9.

Basic Static Load Rating (Co)

The Basic Static Load Rating (Co) is the static load that will permanently cause deformation of the bushing ball track equivalent to 0.01% of the ball diameter. It is good practice to limit the maximum static force to a maximum of 80%.

Short Stroke Life Reduction

Where the stroke distance is less than a Ball Bushing length the calculated life will be reduced by up to 70%.

Lubrication

For best performance, and to achieve a long and trouble free life, ball bushings require lubrication with either oil or grease.

Grease Lubrication

For grease lubrication the anticorrosive protection oil should be removed prior to assembly ensuring that the bearing is dry before applying grease.

Grease should be applied directly to the ball circuits prior to fitting, generally a lithium soap grease ISO viscosity grade 2 is recommended for general use.

Oil Lubrication

For oil lubrication it is not necessary to remove the anticorrosive protection from the bushing. The viscosity grade will be dependent on the operating temperature, please see the chart below.

Operating Temp.	Viscosity
-30° C ~ 50° C	VG 15 ~ 46
50° C ~ 80° C	VG 46 ~ 100

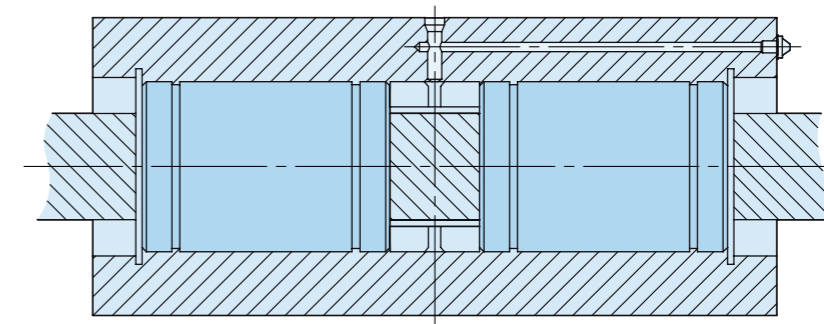

Fig 10. Two Assembled Bushings

For most effective lubrication oil should be applied between two assembled bushings as shown in Figure 10 where seals are fitted only to the outside of each bearing.

Periodic checking of the installation is recommended whether oil or grease is used, in order to check that the bushing is not running dry.

HepcoMotion® Product Range



GV3
Linear Guidance and Transmission System



HDS2
Heavy Duty Slide System

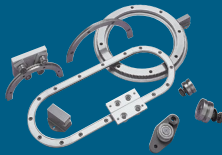

PRT2
Precision Ring and Track System



HDRT
Heavy Duty Ring Slides and Track System

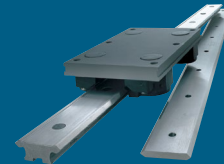

SL2
Stainless Steel Based Slide System

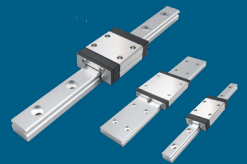

HLG
Hepco Linear Guides



SBD
Sealed Belt Drive



MCS
Aluminium Frame and Machine Construction System

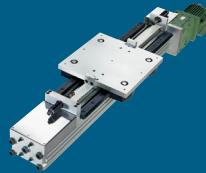

HDLS
Heavy Duty Driven Linear System



DLS
Linear Transmission and Positioning System

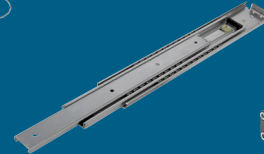

HTS
Telescopic Ball Bearing Slides



HPS
Powerslide-2 Guided Rodless Cylinder

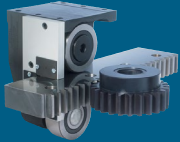

MHD
Heavy Duty Track Roller Guidance System

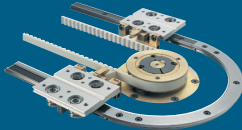

DTS
Driven Track System



BSP
Ballscrew Premier



Simple Select
Vee Slide Linear Guidance Systems

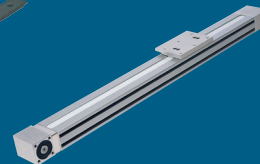

PDU2
Profile Driven Unit

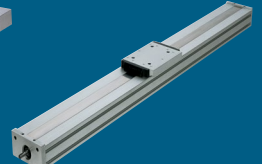

PSD120
Profile Screw Driven Unit

For further information on HepcoMotion® products – please request our leaflet 'FPL'

HepcoMotion®

www.HepcoMotion.com

HepcoMotion® - Deutschland
Schwarzenbrucker Str. 1, 90537
Feucht, Deutschland
Tel: +49 (0) 9128 9271 0
E-mail: info.de@hepcotion.com

HepcoMotion® - Head Office
Lower Moor Business Park, Tiverton Way
Tiverton, Devon, England EX16 6TG
Tel: +44 (0)1884 257000
E-mail: sales@hepcotion.com

HepcoMotion® - España
Edificio Spaces 22@, Calle Pallars, 193,
ES-08005 Barcelona, España
Tel: +34 93 607 22 55
E-mail: info.es@hepcotion.com

HepcoMotion® - Benelux
Doornhoek 3850
5465 TB Veghel, Nederland
Tel: +31 (0) 492 551290
E-mail: info.nl@hepcotion.com

HepcoMotion® - France
64 Chemin de la Chapelle, Saint Antoine
ENNERY, 95300, France
Tel: 01 34 64 30 44
E-mail: info.fr@hepcotion.com

CATALOGUE No. Ball Bushings 02.2 UK © 2022 Hepco Slide Systems Ltd.

Reproduction in whole or part without prior authorisation from Hepco is prohibited. Although every effort has been made to ensure the accuracy of the information in this catalogue, Hepco cannot accept liability for any omissions or errors. Hepco reserves the right to make alterations to the product resulting from technical developments.

Many Hepco products are protected by: Patents, Copyright, Design Right or Registered Design. Infringement is strictly prohibited and may be challenged in law. The Customer's attention is drawn to the following clause in Hepco's conditions of sale:

'It shall be the Customer's sole responsibility to ensure that goods supplied by Hepco will be suitable or fit for any particular application or purpose of the Customer, whether or not such application or purpose is known to Hepco. The Customer will be solely responsible for any errors in, or omissions from, any specifications or information the Customer provides. Hepco will not be obliged to verify whether any such specifications or information are correct or sufficient for any application or purpose.'

Hepco's full conditions of sale are available on request and will apply to all quotations and contracts for the supply of items detailed in this catalogue.

HepcoMotion is the trading name of Hepco Slide Systems Ltd.